

Product information PI 01

Head-type tool turret

Series **0.5.320.0xx**

2014-01-23



Contents

Head-type tool turrets

Series 0.5.320.0xx

Brief description	4
Functional description	5
Technical data.....	6
Dimensions	8
Precision/Permissible loads	10
Working position/ Cooling lubricant supply.....	11
Order information.....	12

Appendix

Wiring diagram Head-type tool turret 0.5.320.0xx – 4 indexing positions.....	EP-442
Wiring diagram Head-type tool turret 0.5.320.0xx.. – 6 indexing positions.....	EP-660
Wiring diagram Head-type tool turret 0.5.320.0xx.. – 8 indexing positions.....	EP-618
Diagram of functions Head-type tool turret 0.5.320.0xx.....	SK-532

Ask for updated documents to determine the appropriate control unit!

Note!

The information contained in this Product Information is in conformity with the knowledge at the point of printing. Subject to modifications which occur within the framework of continuous further development.

Head-type tool turrets

Series 0.5.320.0xx

Brief description

are equipped with four, six or eight tool-holding fixtures involving a “V-block fixture” interface as per DIN 69 881 – formerly VDI 3425-P.3 – depending on the version involved.

Tools: see SAUTER Produkt Information **PI 03**

Turrets 0.5.330.0xx can be supplied for tool-holding fixtures provided with a “parallel shank” interface as per DIN 69 880.

Turrets 0.5.390.0xx may be equipped with special interfaces – for hydraulic tool-clamping devices as well.

Characteristics

- Electromechanical drive via a sturdy and centrally installed asynchronous three-phase AC motor
- Reliable block-locking device by means of 3-part crown gears
- Turret sense of rotation counterclockwise - clockwise, on request
- Mounting position as desired
- Internal cooling lubricant supply to each active tool respectively involved
- Grease-lubricated for life
- Degree of protection IEC 529 – IP 67
- Special versions with fluid rotary supply, too

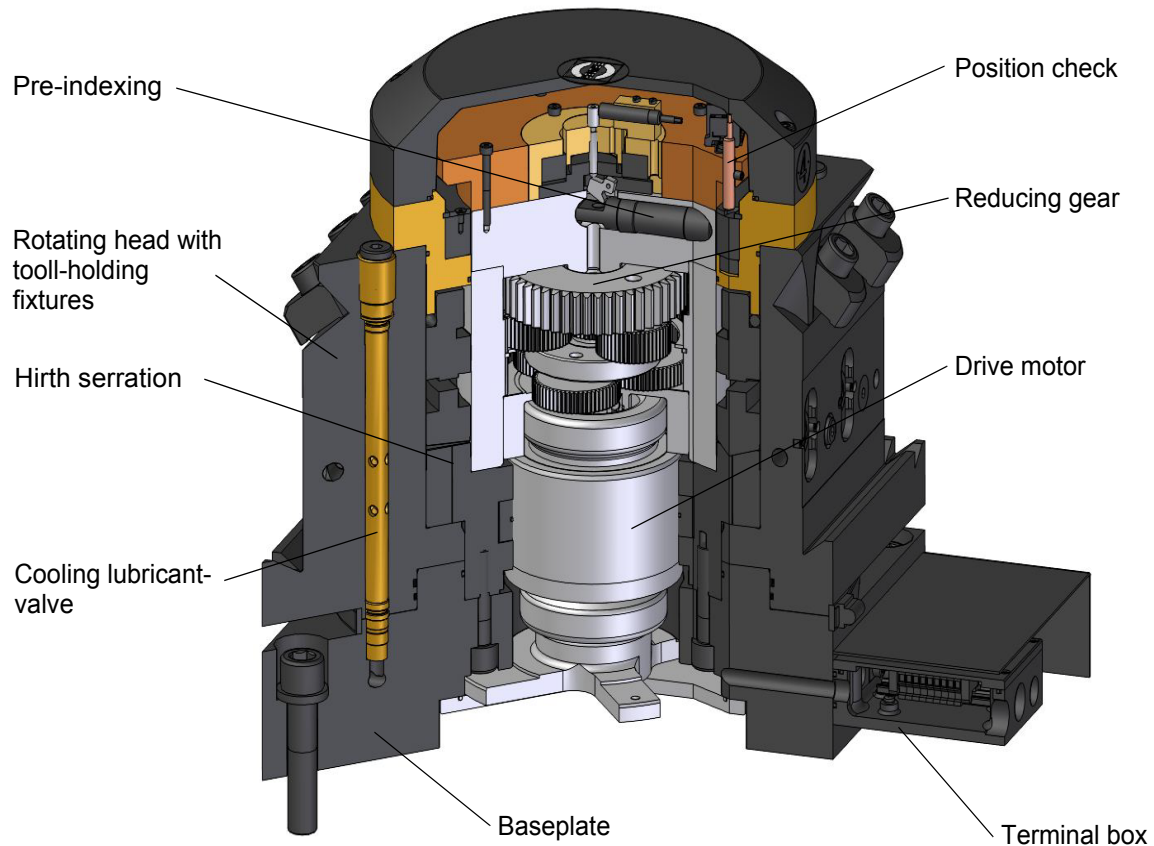

Functional description

The turret motor drives the swiveling rotating turret head via a three-stage reducing gear. The preindexing process is initiated by a solenoid, just before the required position is reached, and the rotating head revolution is stopped by means of buffer elements.

The contrarotating motor revolution causes the turret to be accurately locked, when the crown gears are axially joined, if the preindexing device is switched on.

The incorporated DC injection brake maintains the shutdown motor in position, thus preventing the turret from being unintentionally unlocked.

The displacement position of the rotating turret head is registered by position switches.

Each tool-holding fixture is supplied with cooling lubricant, when placed in working position. The supply line is connected to the screwed pipe connections on the baseplate.

Technical data

Series		Size	
Head-type tool turret		16	
Number of indexing positions ¹⁾		4	6
Nominal tool-holder size			
Standard I as per DIN 69 881 (=VDI 3425-1)		90 (25)	90 (25)
Standard II as per DIN 69 881 (=VDI 3425-1)			
Permissible loads			
perm. axial loads	kN	10	
Distance to turret axis	mm	180	
perm. tangential loads	kNm	1,6	
perm. mass moment of inertia			
Load range: standard	kgm ²	0,7	
Load range: high loads	kgm ²	1,6	
perm. tooling mass	kg	20	
perm. unbalance on horizontal axis	Nm	16	
Indexing times ^{3) 4)}	→ <i>Diagram of functions SK-532 in the Appendix</i>		
Load range: standard			
per indexing stage Release 1 ⁵⁾ (Release 2 ⁶⁾)	s	1,38(1,68)	1,1(1,4)
per additional indexing stage	s	0,83	0,55
Load range: high loads			
per indexing stage Release 1 ⁵⁾ (Release 2 ⁶⁾)	s	2,0 (2,3)	1,6 (1,9)
per additional indexing stage	s	1,25	0,85
per indexing frequency ($\varphi_m = 90^\circ$)			
Load range: standard	min ⁻¹	7,5	
Load range: high loads	min ⁻¹	5,5	
perm. operating pressure for cooling lubricant ⁷⁾			
constantly/with stoppage on swiveling	bar	25 Filtering $\leq 100\mu\text{m}$	
Mass			
Turret (without any tooling)	kg	40	

- 1) The turrets may be supplied with 6 or 8 indexing positions on request
- 2) For a mains frequency of 50 Hz only
- 3) Values applicable to drives designed for mains frequencies of 50 Hz and 60 Hz
- 4) Values higher by approx. 20% with drives designed for mains frequencies of 60 Hz
- 5) 90% of perm. tangential loads achieved
- 6) 100% of perm. tangential loads achieved
- 7) higher pressures on request

Size											
20			25			32			40		
4	6	8	4	6	8	4	6	8	4	6	8
90 (25)	90 (25)	90 (25)	115 (32)	115 (32)	115 (32)	140 (40)	140 (40)	140 (40)	140 (40)	140 (40)	140 (40)
115 (32)			140 (40)								
15			25			50			80		
220			280			350			450		
3,2			6,3			12,5			25		
2	2,5	2	5,5 ⁴⁾			18 ⁴⁾			50		
4,5	4,5	4,5	10 ²⁾			40 ²⁾			100		
35			63			110			200		
25			50			100			160		
1,38(1,68)	1,28(1,58)	0,97(1,27)	2,0(2,3) ⁴⁾	1,6(1,9) ⁴⁾	1,4(1,7) ⁴⁾	2,6(3,0) ⁴⁾	2,05(2,45)	1,8(2,2) ⁴⁾	3,0(3,4)	2,35(2,75)	2,05(2,43)
0,83	0,66	0,42	1,25 ⁴⁾	0,85 ⁴⁾	0,65 ⁴⁾	1,7 ⁴⁾	1,1 ⁴⁾	0,85 ⁴⁾	2,0	1,3	1,0
2,05(2,35)	1,63(1,95)	1,45(1,75)	2,6(2,9)	2,05(2,35)	1,8(2,1)	3,8(4,2)	3,0(3,4)	2,6(3,0)	3,95(4,35)	3,1(3,5)	2,65(3,05)
1,3	0,87	0,65	1,7	1,1	0,85	2,5	1,7	1,3	2,6	1,75	1,3
6			5			4			3		
5			3,5			3			2		
25 Filtering ≤ 100µm											
75	115	70	110 (32) 140 (40)	130	125	250	230	220	420	400	380

Dimensions

4 indexing positions
Working position 90°/180°/270°

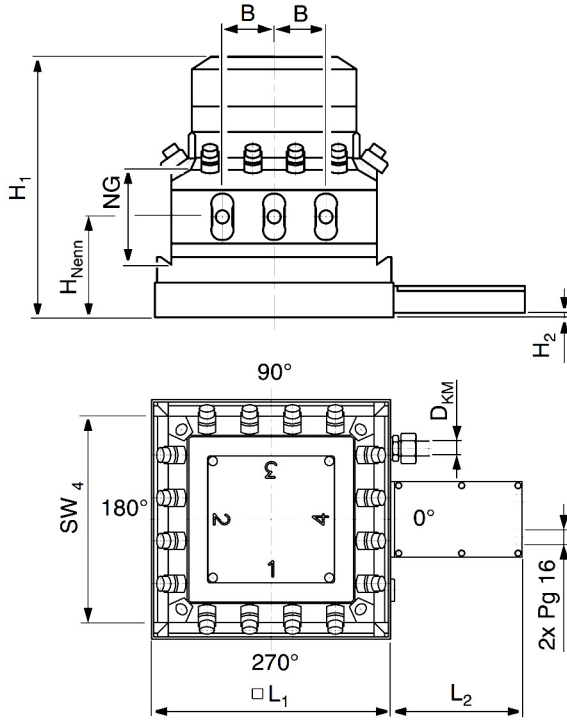

6 indexing positions
WDiffering working position corresponds to different version of head type turret
Working position 90°/270°

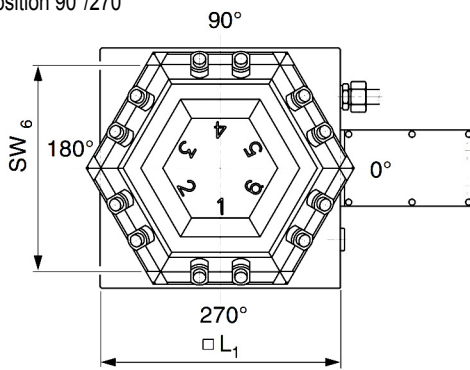

Working position 180°

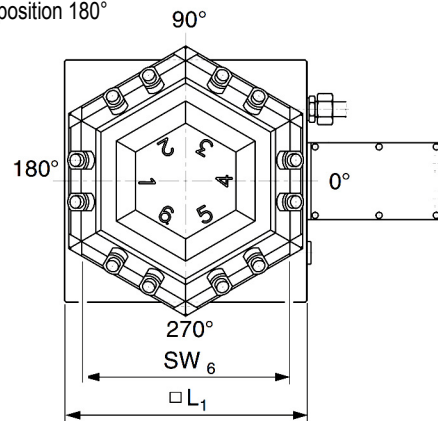

8 indexing positions
Working position 90°/180°/270°

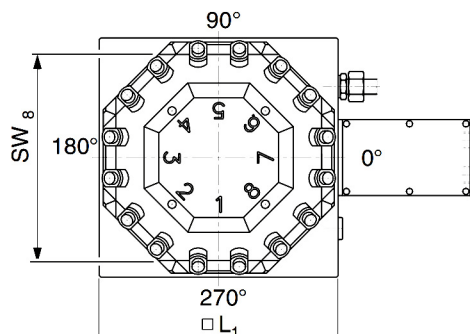

Series	Size					
	16	20	25	32	40	
Head-type tool turret 0.5.320.0xx	16	20	25	32	40	
SW ₄	160	200	250	320	400	
SW ₆	160	265	250	320	400	
SW ₈	-	200	270	320	400	
NG DIN 69880 (= VDI 3425-1)	90 (25)	90 (25)	115 (32)	115 (32)	140 (40)	140 (40)
□ L ₁	195	235	290	365	460	
L ₂	160	160 ¹⁾	126	126	126	
H _{Nenn}	98	110	122	122	156	196
H ₁	242	288	320	338	410	425
H ₂	-9	1	-10	22	18	
B	40	50	63	80	120	
D _{KM}	12	15	18	22	28	

1) with 6 indexing positions (SW₆ = 265) L₂ = 172

dimensions in mm

Precision

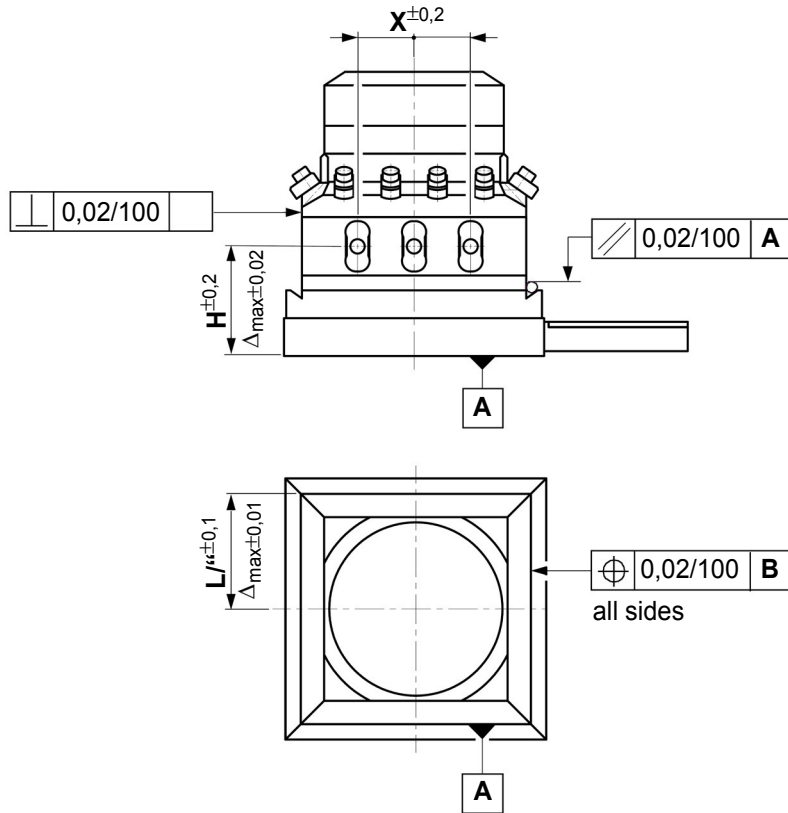

Repetitive precision
when swiveling turret
radius of $\pm 0,8\text{mm} / 100\text{mm}$

Dimension in mm

Permissible loads

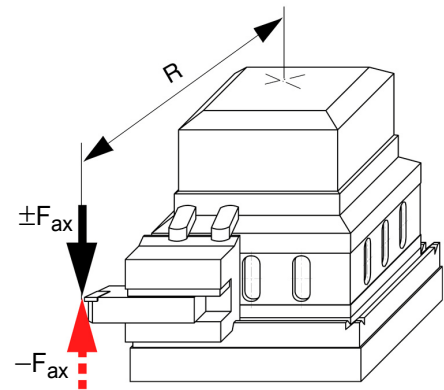
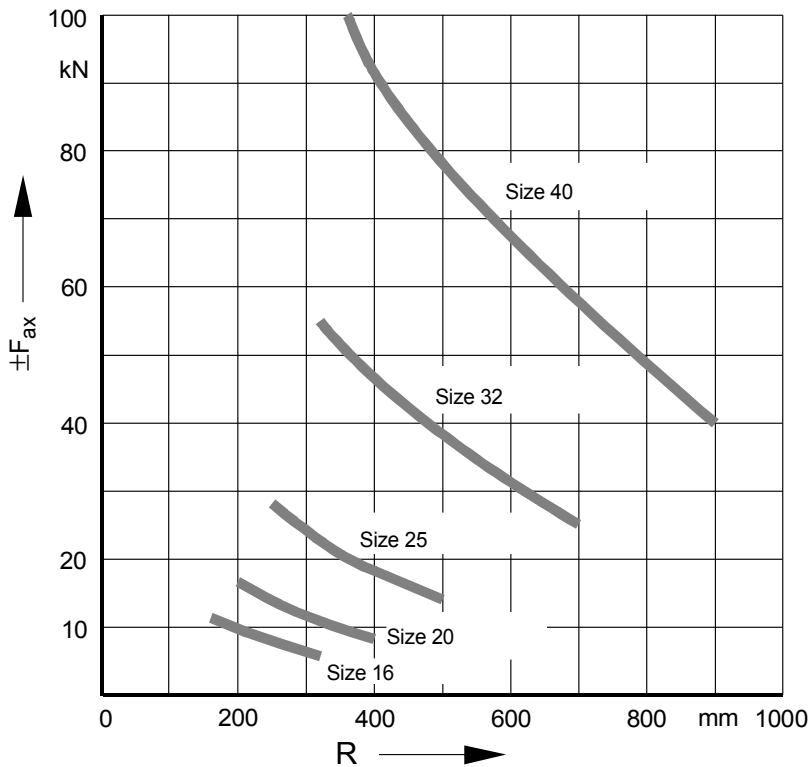

Workingposition

Cooling lubricant supply

Each position standing opposite the terminal box and/or laterally can be determined as a working position (to be stated in the order!). As a result, the cooling lubricant supply for the tool-holding fixtures is to be determined, too.

Turret with 4 indexing positions

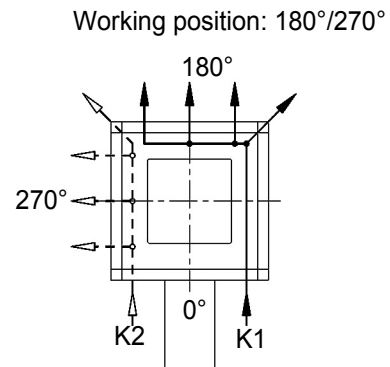
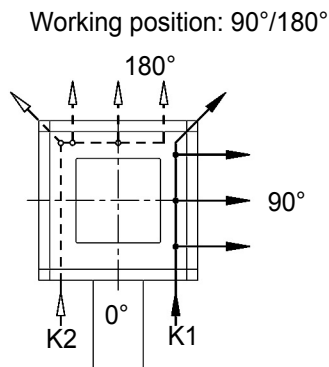

The cooling lubricant supply system can be modified at a later stage by replacing various plugs on the rotating head.

Turret with 6 indexing positions

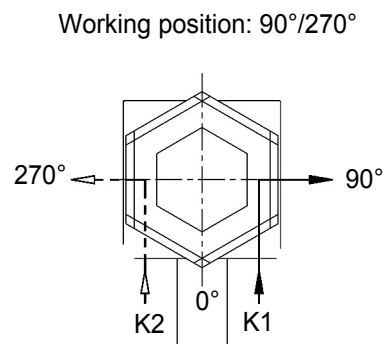
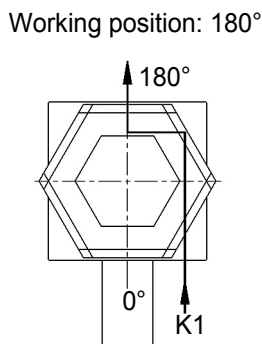

Turret with 8 indexing positions

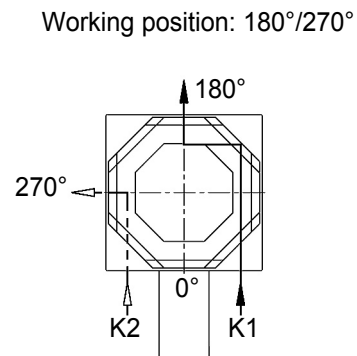
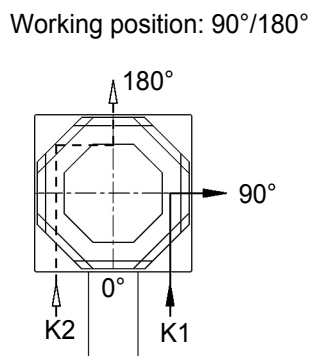

Cooling lubricant connection:

On screw connections K1 and/or K2 on the baseplate

Cooling lubricant outlets:

- Delivery valve on each tool-holding fixture
- Plus a pipe connection on each lateral rotating-head surface

Contact/Order information



++49 (0) 7123-926-190



++49 (0) 7123-926-0



info@sauter-feinmechanik.com



Sauter Feinmechanik GmbH
Postfach 1551
D-72545 Metzingen
Germany

Company: _____

Street: _____

Postcode, City: _____

Name: _____

Phone: _____



Fax: _____

e-mail: _____

SAUTER Head-type tool turret 0.5.320.0xx			
Order information	Possible variants		Your selection!
Size	16 / 20 / 25 / 32 / 40		1 <input type="checkbox"/> 2 <input type="checkbox"/> 2 <input type="checkbox"/> 3 <input type="checkbox"/> 4 <input type="checkbox"/>
Number of indexing positions	4 / 6 / 8		4 <input type="checkbox"/> 6 <input type="checkbox"/> 8 <input type="checkbox"/>
Tool-holding fixture	DIN 69 881		<input type="checkbox"/>
	DIN 69 880		<input type="checkbox"/>
	Special		<input type="checkbox"/>
Nominal tool-holder size → Page 6 / 7	DIN 69 881 - NG ...		
Sense of rotation	counterclockwise		<input type="checkbox"/>
	(clockwise)		<input type="checkbox"/>
Load range → Page 6 / 7	Standard		<input type="checkbox"/>
	High loads		<input type="checkbox"/>
Mains voltage	400 V	460 V	...
Mains frequency	50 Hz	60 Hz	...
Working position → Page 11	90° / 180° / 270°		<input type="checkbox"/>
Special requirements 			
Quantity		

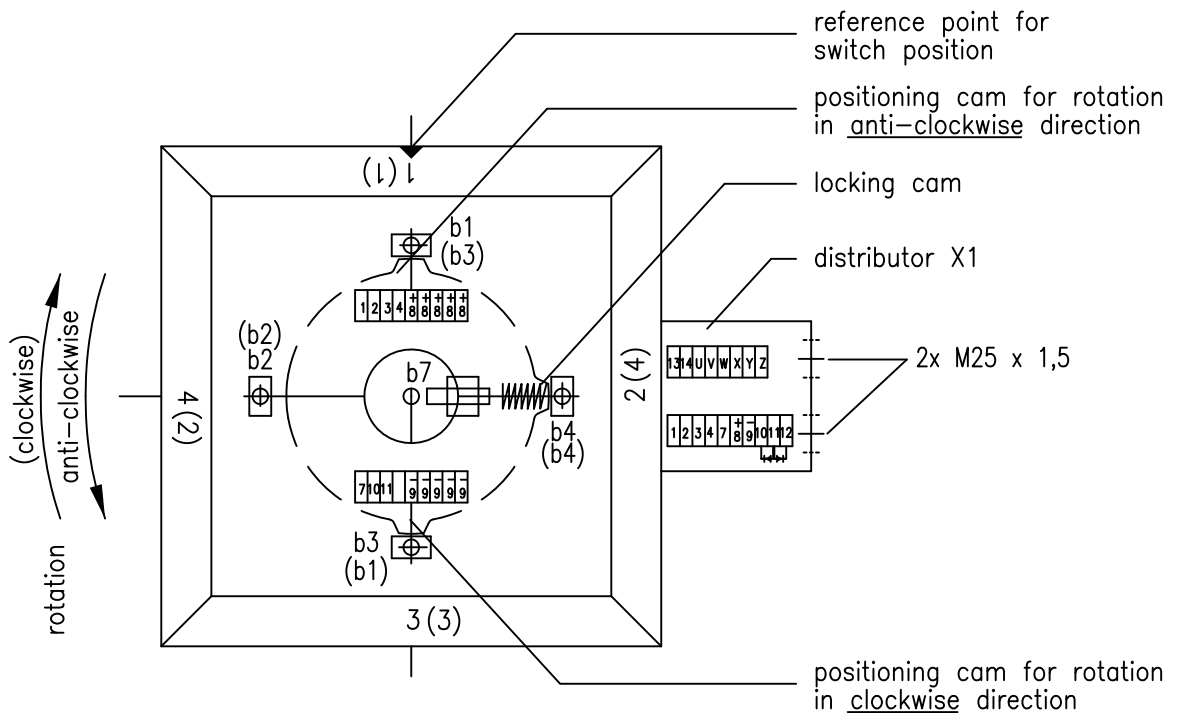
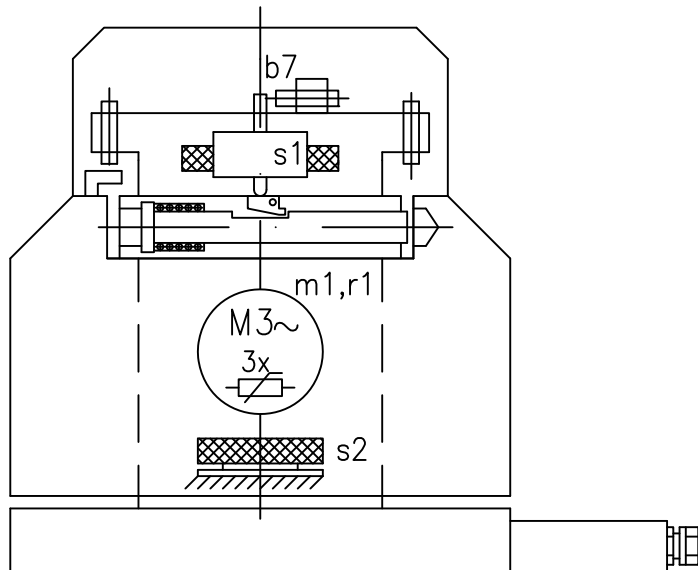
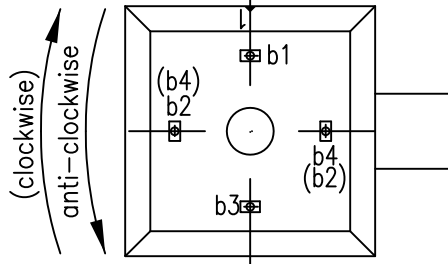
Information: Proximity-Detector
installation position until 12/99



Designation	Element/Function	Line from element	Terminal X1	④ Cable 18x0,75mm ²	Type	Supplier	
b1	Proximity-Detector Control turret position and locking 1	brown (+)	8	8	M8x45 Id. Nr. 4157		
		blue (-)	9	9			
		black	1	1			
b2	Proximity-Detector Control turret position and locking 2	brown (+)	8		M8x45 Id. Nr. 4157		
		blue (-)	9				
		black	2	2			
b3	Proximity-Detector Control turret position and locking 3	brown (+)	8		M8x45 Id. Nr. 4157		
		blue (-)	9				
		black	3	3			
b4	Proximity-Detector Control turret position and locking 4	brown (+)	8		M8x45 Id. Nr. 4157		
		blue (-)	9				
		black	4	4			
b7	Proximity-Detector Control pre-indexing	brown (+)	8		M8x45 Id. Nr. 4157		
		blue (-)	9				
		black	7	7			
r1	① Posistor-heat detector	blue	13	13	PTC-Thermistor DIN 44081 U _≤ 4V DC	SAUTER	
m1	3-Phase A.C. Motor (release-indexing- locking)	②	U	15	sz 012 0,4/0,55A sz 016 0,6/0,85A sz 020 0,8/1,1A sz 025 1,6/2,2A sz 032 1,1/2,2A sz 040 1,45/2,5A		Standard 380V 50Hz
			V	16			
			W	17			
			X				
			Y				
			Z				
s1	Solenoid pre-indexing	brown (+) 	③ 10	10	24V DC, 50% ED to size 012 28W, from size 016 42W		
	blue (-)	11	11				
s2	Solenoid controlled disk brake	blue (-) 	③ 11		sz 012 5,3W sz 016 5,3W sz 020 6,5W sz 025 8,0W sz 032 8,3W sz 040 12W	24VDC	
		brown (+)	12	12			
	Ground		⊥	ye-gn			

① for this, protective motor switch (thermistor) is required. Without thermistor motor protector no guarantee in case of motor failure.

③ Diode 1N4006 (mounted to terminals).

④ depending on the turret's outfit.

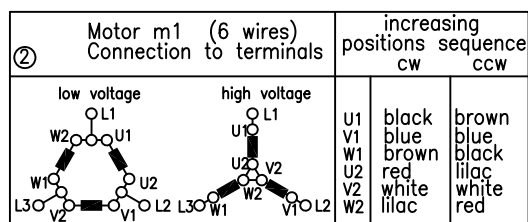

Technical Data of:		b1-b7
Operating voltage:	10-24 V DC ±20%	
Max. residual ripple:	10%	
Max. load current:	200mA	
Nom. sensing distance:	1mm	
Temperature range:	-20° bis + 65°C	
Function:	n.o. (make) function	
Type:	pnp logic	

Information: Proximity-Detector
installation position until 12/99

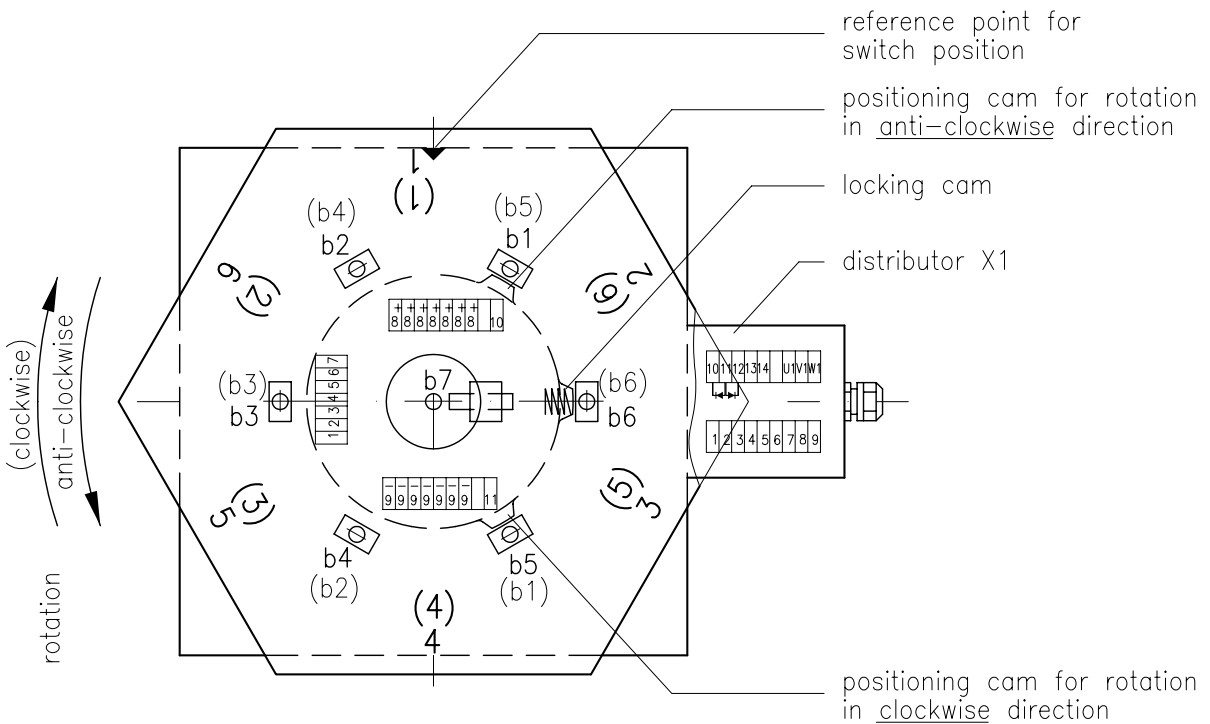
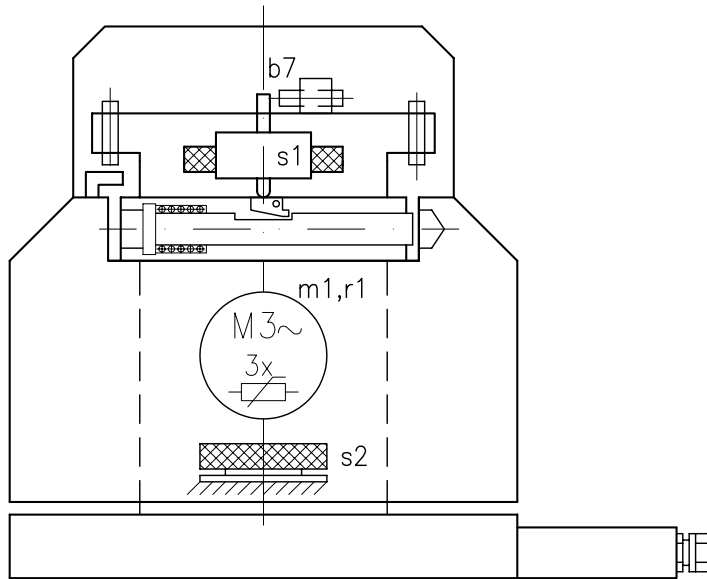
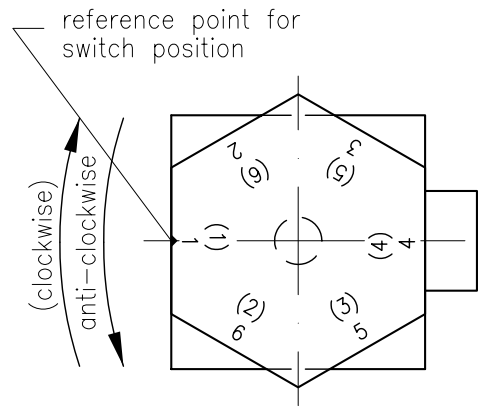
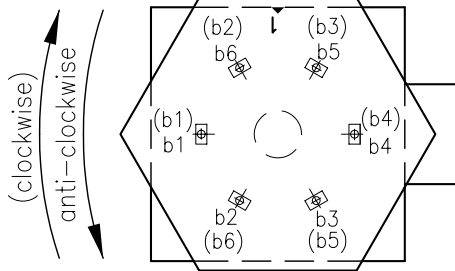

Designation	Element/Function	Line from element	Terminal X1	④ Cable 18x0,75mm ²	Type	Supplier	
b1	Proximity-Detector Control turret position and locking	1 brown (+)	8	8	M8x45 Id. Nr. 4157		
		blue (-)	9	9			
		black	1	1			
b2	Proximity-Detector Control turret position and locking	2 brown (+)	8		M8x45 Id. Nr. 4157		
		blue (-)	9				
		black	2	2			
b3	Proximity-Detector Control turret position and locking	3 brown (+)	8		M8x45 Id. Nr. 4157		
		blue (-)	9				
		black	3	3			
b4	Proximity-Detector Control turret position and locking	4 brown (+)	8		M8x45 Id. Nr. 4157		
		blue (-)	9				
		black	4	4			
b5	Proximity-Detector Control turret position and locking	5 brown (+)	8		M8x45 Id. Nr. 4157		
		blue (-)	9				
		black	5	5			
b6	Proximity-Detector Control turret position and locking	6 brown (+)	8		M8x45 Id. Nr. 4157		
		blue (-)	9				
		black	6	6			
b7	Proximity-Detector Control pre-indexing	7 brown (+)	8		M8x45 Id. Nr. 4157		
		blue (-)	9				
		black	7	7			
r1	① Posistor-heat detector	blue	13	13	PTC-Thermistor DIN 44081 U _≤ 4V DC		
		blue	14	14			
m1	3-Phase A.C. Motor (release-indexing- locking)	②	U1	15	sz 012 0,4/0,55A sz 016 0,6/0,85A sz 020 0,8/1,1A sz 025 1,6/2,2A sz 032 1,1/2,2A sz 040 1,45/2,5A	Standard 380V 50Hz	SAUTER
			V1	16			
			W1	17			
			U2				
			V2				
			W2				
s1	Solenoid pre-indexing	brown (+)	10	10	24V DC, 50% ED to size 012 28W, from size 016 42W		
		blue (-)	11	11			
s2	Solenoid controlled disk brake	blue (-)	11		sz 012 5,3W sz 016 5,3W sz 020 6,5W sz 025 8,0W sz 032 8,3W sz 040 12W	24VDC	
		brown (+)	12	12			
	Ground		⊥	ye-gn			

① for this, protective motor switch (thermistor) is required. Without thermistor motor protector no guarantee in case of motor failure.

③ Diode 1N4006 (mounted to terminals).

④ depending on the turret's outfit.

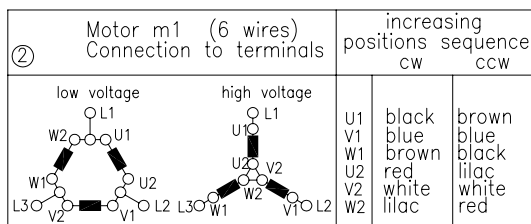

Technical Data of:		S1-S7
Operating voltage:	10-24 V DC ±20%	
Max. residual ripple:	10%	
Max. load current:	200mA	
Nom. sensing distance:	1mm	
Temperature range:	-20° bis + 65°C	
Function:	n.o. (make) function	
Type:	pnp logic	

Information: Proximity-Detector
installation position until 12/99

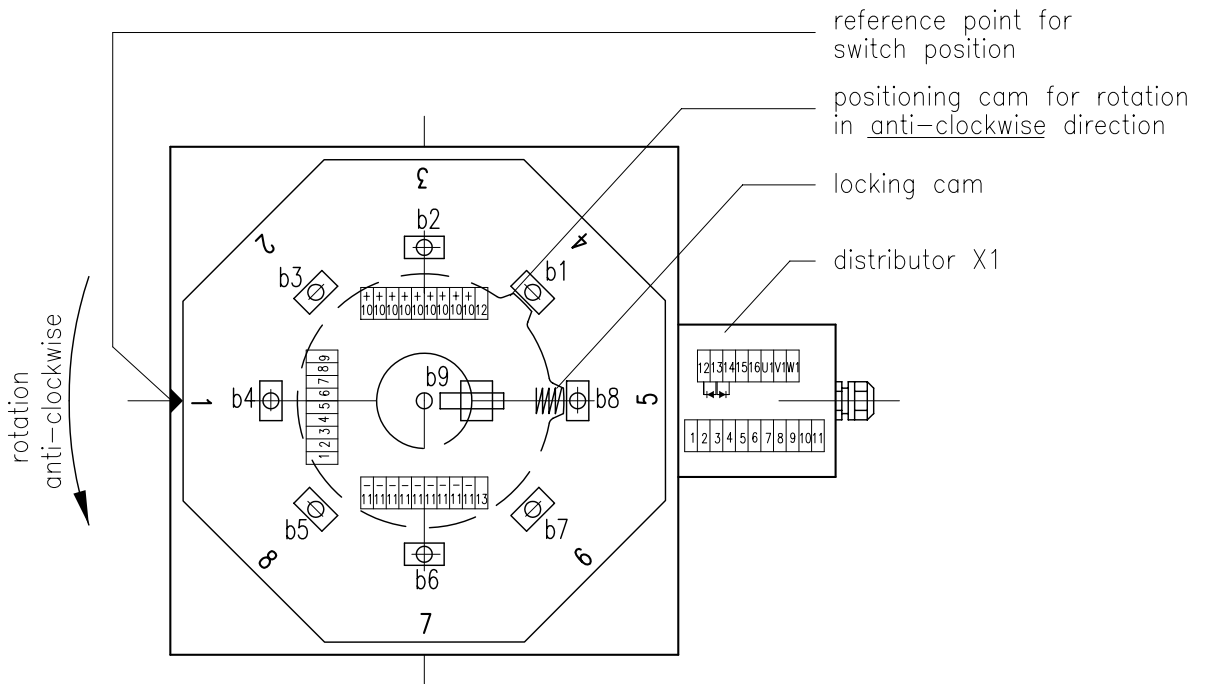
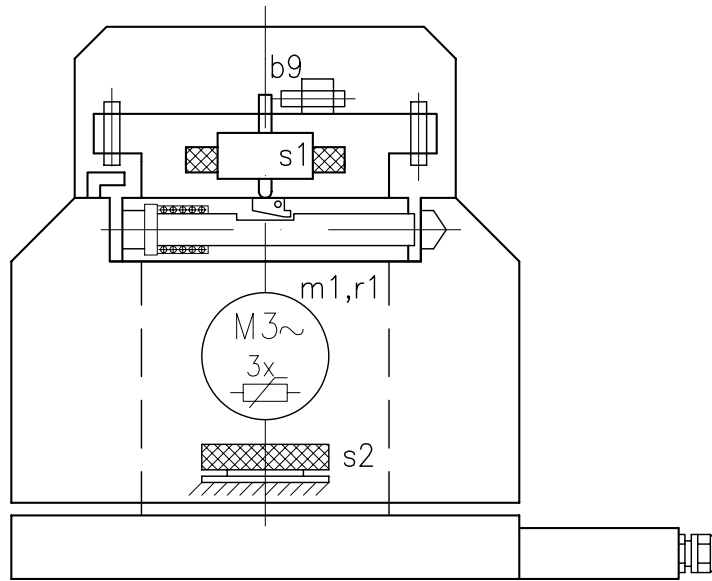
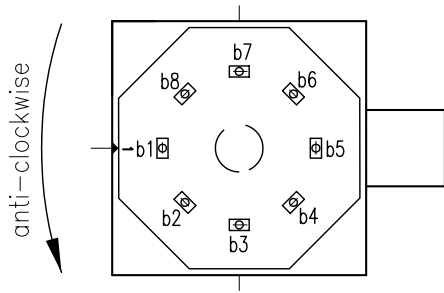

Designation	Element/Function	Line from element	Terminal X1	④ Cable 25x0,75mm ²	Type	Supplier		
b1	Proximity-Detector Control turret position and locking	1	brown (+)	10	10	M8x45 Id. Nr. 4157		
			blue (-)	11	11			
			black	1	1			
b2	Proximity-Detector Control turret position and locking	2	brown (+)	10		M8x45 Id. Nr. 4157		
			blue (-)	11				
			black	2	2			
b3	Proximity-Detector Control turret position and locking	3	brown (+)	10		M8x45 Id. Nr. 4157		
			blue (-)	11				
			black	3	3			
b4	Proximity-Detector Control turret position and locking	4	brown (+)	10		M8x45 Id. Nr. 4157		
			blue (-)	11				
			black	4	4			
b5	Proximity-Detector Control turret position and locking	5	brown (+)	10		M8x45 Id. Nr. 4157		
			blue (-)	11				
			black	5	5			
b6	Proximity-Detector Control turret position and locking	6	brown (+)	10		M8x45 Id. Nr. 4157		
			blue (-)	11				
			black	6	6			
b7	Proximity-Detector Control turret position and locking	7	brown (+)	10		M8x45 Id. Nr. 4157		
			blue (-)	11				
			black	7	7			
b8	Proximity-Detector Control turret position and locking	8		10		M8x45 Id. Nr. 4157		
				11				
				8	8			
b9	Proximity-Detector Control pre-indexing			10		M8x45 Id. Nr. 4157		
				11				
				9	9			
r1	① Posistor-heat detector	blue	15	15	PTC-Thermistor DIN 44081 U _e 4V DC			
		blue	16	16				
m1	3-Phase A.C. Motor (release-indexing- locking)	②		U1	17	sz 012 0,4/0,55A sz 016 0,6/0,85A sz 020 0,8/1,1A sz 025 1,6/2,2A sz 032 1,1/2,2A sz 040 1,45/2,5A	Standard 380V 50Hz	SAUTER
				V1	18			
				W1	19			
				U2				
				V2				
				W2				
s1	Solenoid pre-indexing		brown (+)	③ 12	12	24V DC, 50% ED to size 012 28W, from size 016 42W		
			blue (-)	③ 13	13			
s2	Solenoid controlled disk brake		blue (-)	③ 13		sz 012 5,3W sz 016 5,3W sz 020 6,5W sz 025 8,0W sz 032 8,3W sz 040 12W	24VDC	
			brown (+)	③ 14	14			
	Ground		⊥	ye-gn				

① for this, protective motor switch (thermistor) is required. Without thermistor motor protector no guarantee in case of motor failure.

③ Diode 1N4006 (mounted to terminals).

④ depending on the turret's outfit.

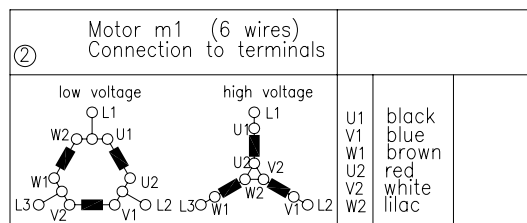

Technical Data of: b1-b9

Operating voltage:	10-24 V DC ±20%
Max. residual ripple:	10%
Max. load current:	200mA
Nom. sensing distance:	1mm
Temperature range:	-20° bis + 65°C
Function:	n.o. (make) function
Type:	pnp logic

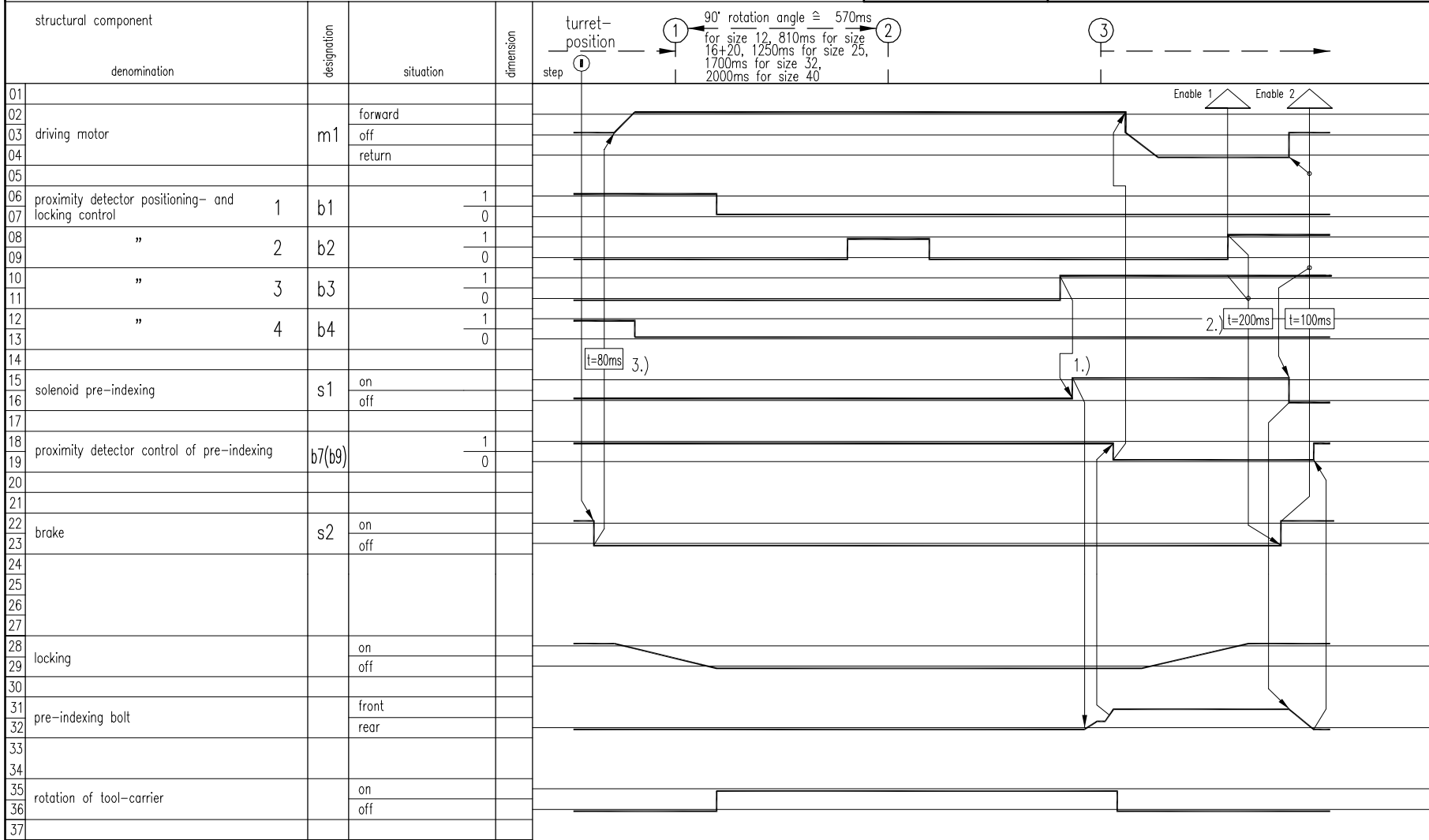

see also: EP-442 4-positions
EP-660 6-positions
EP-618 8-positions
note

shown function:
cycle motion from indexing pos.1 to indexing pos.3

time indication relative to 50 cy standard type

shown function:
positioning control for turret 4 tools

(b9) designation for turret 8 tools

● emergency cut off: driving motor "off"

tables of functions proximity detector "positioning- and locking control"

proximity detector	turret 4 tools				turret 6 and 8 tools											
	1	2	3	4	turret 6 tools				turret 8 tools							
turret-position	1	2	3	4	1	2	3	4	1	2	3	4	5	6	7	8
b1	1	0	0	0	1	1	0	0	1	1	0	0	1	1	0	0
b2	0	1	0	0	0	1	1	0	0	1	0	0	0	1	0	0
b3	0	0	1	0	0	0	1	1	0	0	1	0	0	0	1	0
b4	0	0	0	1	1	0	0	1	0	0	1	1	0	0	0	0
b5					0	0	0	1	0	0	0	1	1	0	0	0
b6					0	0	0	0	1	0	0	0	0	0	0	1
b7					0	0	0	0	0	1	0	0	0	0	0	1
b8					0	0	0	0	0	1	1	0	0	0	0	0

* for turret 6 tools

- 1.) max. retardation between signal b.. and s1 on 30ms
- 2.) at size 032/040 t=300ms (20.10.93)
- 3.) for more safety, time for brake releasing t=80ms recommended (25.11.93)